



Softail Sideshots Exhaust System Part #26005

Congratulations, you have purchased the finest exhaust system available for your motorcycle. Your VANCE & HINES exhaust system is designed and crafted for maximum performance, a perfect fit, a great sound and unbeatable style! Please follow the installation instructions below and if you have any questions, feel free to call our technical help line (562) 926-5291.

Attention Installer: (if other than owner): Please forward this instruction sheet to the purchaser of this product. These instructions contain valuable information necessary to the end user.



STOCK EXHAUST SYSTEM REMOVAL

1. On FLSTN, FLSTF, FLSTH and FLSTC loosen the right hand floor board mounting bolts to gain clearance for exhaust removal and installation.
2. Loosen the heat shield clamps on both front and rear exhaust pipes.
3. Loosen the crossover pipe clamp, located between the front and rear head pipe. (Not necessary on 2000-up models).
4. Remove the two mounting nuts from each head pipe, located at the cylinder head.

5. Remove the bolts attaching the mufflers to the frame.
6. Remove the entire exhaust system and set it aside.
7. On pre 2000 models remove the lower mounting bar.
8. FLSTN, FLSTF and FXSTD models have an upper mounting bar that must be removed in addition to the lower bar. On pre 2000 models go to step #9, on 2000-up models go to step #10.
9. Remove the right passenger foot peg bolt. Position the motorcycle on the side stand with a floor jack under the swing arm pivot bolt on the right hand side. Raise the jack just enough to take the weight off the pivot bolt, remove the bolt and stock mounting bar. Reinstall the pivot bolt and torque to 120 -150 ft. lbs. Reinstall the passenger foot peg using the 1/2" x 3" Allen bolt and 1-5/8" length spacer (supplied).
10. Using a #50 Torx driver, remove the three mounting bolts, and set the mounting bar aside. (Two of the bolts are visible, the third is accessed by removing the right hand passenger foot peg.) Replace the foot peg using the 3/8" x 2 1/2" Allen bolt and 3/4" length spacer (supplied).
11. The bolts and spacers used in the above steps may also be used on all Softail models to space the right rear foot peg away from the exhaust.
12. Carefully remove the flanges and circlips from the stock exhaust system using snapping pliers (save for re-use). **NOTE: If circlips look bent or twisted replace them with new circlips.**

VANCE & HINES EXHAUST SYSTEM INSTALLATION

1. Check condition of stock exhaust gaskets. Replace if damaged or worn. Vance & Hines recommends you replace your gaskets with Screamin' Eagle gaskets part number 17048-98.
2. Remove head pipes and heat shields from protective packaging. Place each heat shield on a non-abrasive surface such as a blanket or carpet. Using a felt tip pen, mark outside edge of each heat shield to show location of hose clamp mounting clips (Figure 1).
3. Lay heat shields (part # D300HC and D301HC) onto headers (Figure 2) and loosely install hose clamp into heat shield clips. Take note of screw head direction (Figure 3). Screw head should be accessible when system is installed on motorcycle for adjustment purposes. Use #20 hose clamps for head pipe areas and #28 hose clamps for muffler areas. **NOTE: Do not tighten at this time.**

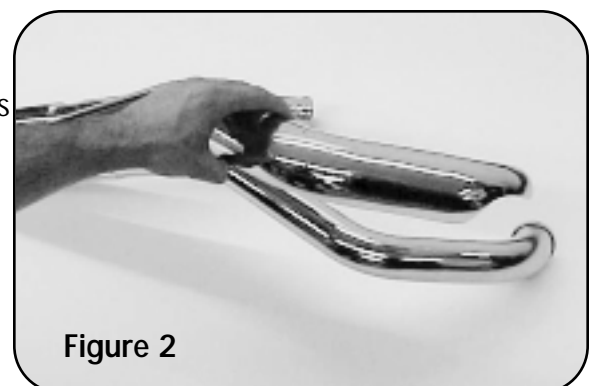
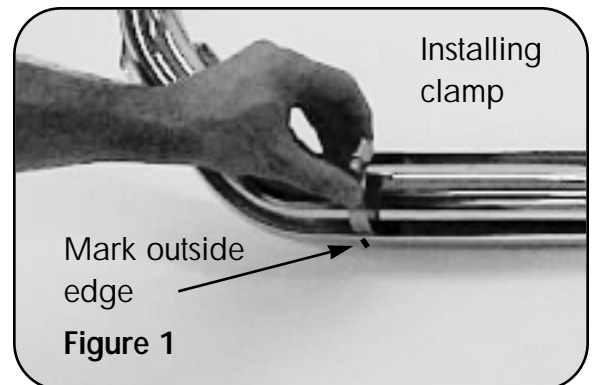

4. Install circlips and flanges from the stock system onto both new head pipes.

5. Slide nut plates inside bracket that is welded to backside of muffler bodies. Install, but do not tighten, supplied mounting bracket 350-P to the muffler bodies, using four 5/16"x5/8" flange bolts (supplied) (Figure 4).

6. Using stock flange nuts, carefully install head pipes into exhaust ports, starting with the rear cylinder. (Assistance may be required). **NOTE:** Do not tighten at this time.

7. Install, but do not tighten, supplied mounting bracket 350-P to the two lower holes in the frame below the right passenger footrest, using two 3/8" x 3/4" flange bolts (supplied).

8. Tighten cylinder port exhaust flange nuts on front and rear cylinders.

9. Tighten flange bolts securing mount bracket 350-P to frame.

10. Tighten flange bolts securing muffler bodies to mount bracket 350-P.

11. Tighten all heat shield clamps.

12. Check for adequate clearance between all exhaust system components and motorcycle accessories prone to heat damage.

13. Retighten floor board mounting bolts on models so equipped.

14. **Be sure to tighten all hardware before starting motorcycle.**

RE-JETTING INSTRUCTIONS

Re-jetting the carburetors will result in realizing the "full" potential of this performance exhaust system. Vance & Hines offers jet kits for most applications. For fuel injected models, we recommend the use of Vance & Hines Fuelpak part number 61001.

PLEASE NOTE:

Every effort is made for Vance & Hines Exhaust Systems to provide improved cornering clearance. However, due to design and space limitations on some motorcycle models, ground and cornering clearance may not be improved and in some cases may be reduced. Be sure to follow proper installation instructions.

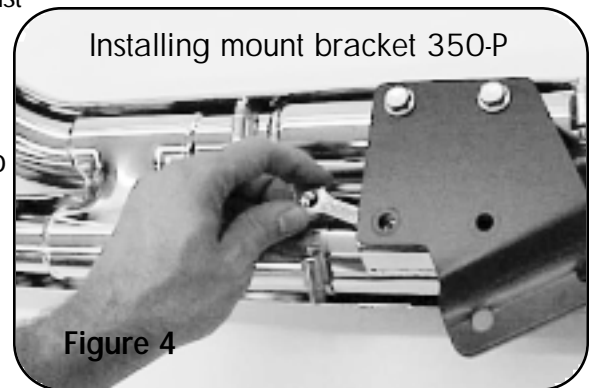
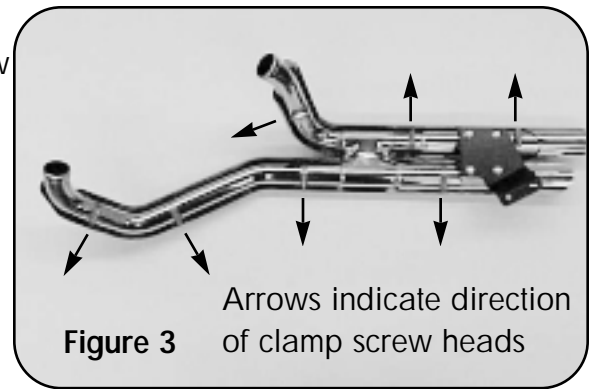

Option

On fuel injected models this system will work with Vance & Hines Fuelpak part number 61001. Order it today from your dealer or go to vanceandhines.com for more information.

Fuelpak
FUEL MANAGEMENT SYSTEM

Option

Vance & Hines also offers Quiet baffles for this system, part number 21301. This will lower the sound level 2-3db on average. Order it today from your dealer or go to vanceandhines.com for more information.

PACKING LIST (All parts actual size)

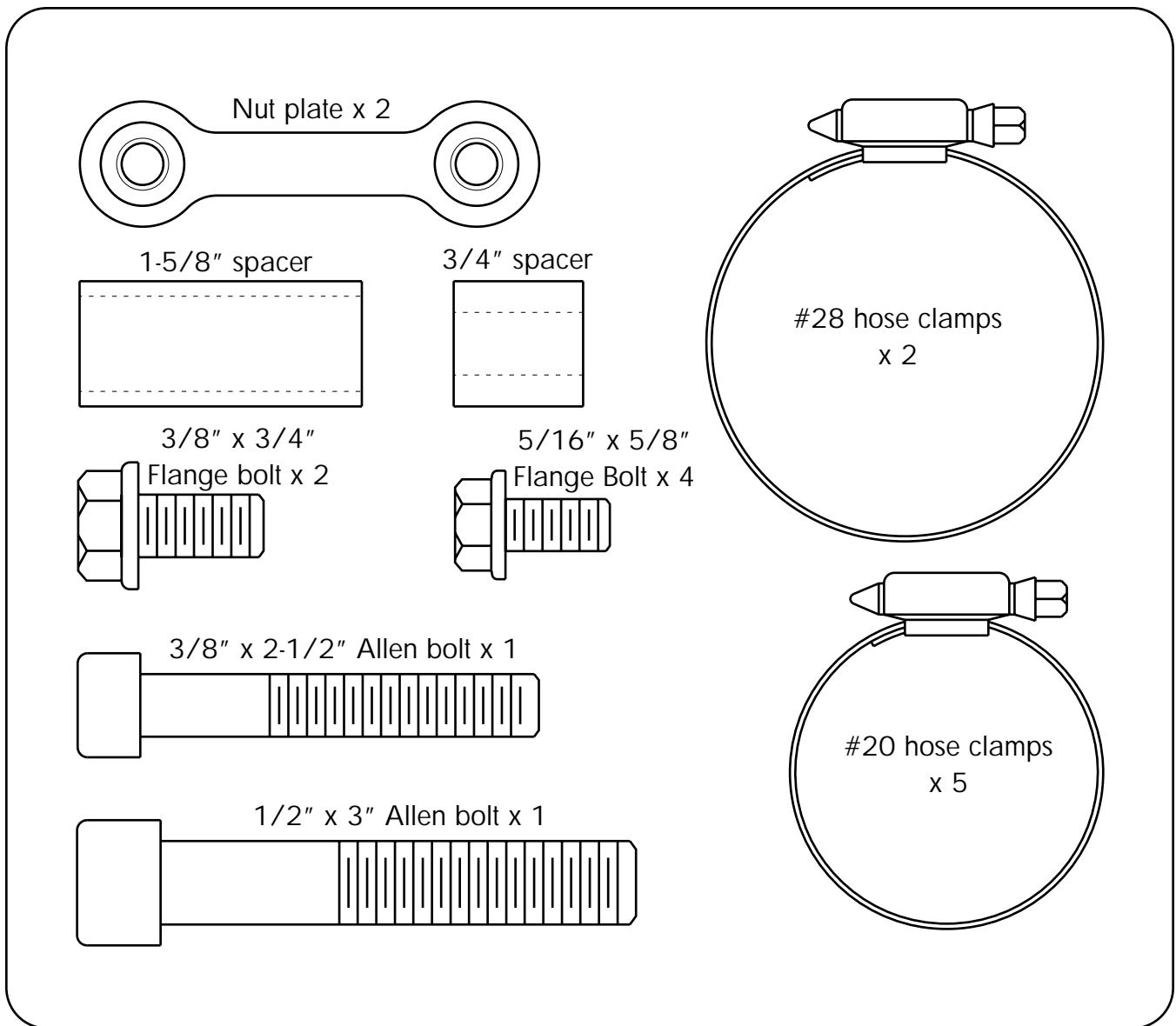

HELPFUL HINTS TO AVOID DISCOLORATION OF EXHAUST PIPES

1. Follow owner's manual instructions regarding use of the choke (starter enricher). If left on longer than recommended, discoloration may be accelerated.
2. Avoid long periods of idling.
3. Intake leaks can cause engine to run lean and overheat, thus turning the pipes blue.
4. Make sure there are no exhaust leaks at the junction of the exhaust pipe and cylinder head.
5. When installing a new set of chrome pipes, make sure your hands are clean and free of oil. After installation, thoroughly clean pipes with a cleaning solvent that will leave no residue (glass cleaner, alcohol, ammonia, etc.) before starting the motorcycle.

WARNING!

VANCE & HINES DOES NOT WARRANTY ANY CHROME PRODUCTS AGAINST DISCOLORATION.

For information on other Vance and Hines products visit our web site at www.vanceandhines.com