

MORE POWER : LESS NOISE

**STOCK EXHAUST SYSTEM REMOVAL
AND XCR INSTALLATION**



Congratulations, you have purchased the finest exhaust system for your motorcycle on the market. Your Vance & Hines exhaust system is designed and crafted for maximum performance, a perfect fit, a great sound and unbeatable style. Please follow the installation instructions below and if you have any questions, please call our technical support line at (562) 926-5291.

Attention installer (if other than owner), please forward this instruction sheet to the owner of this product. These instructions contain valuable information to the end user.

**BEFORE
YOU BEGIN**

- It's always a good idea to clean your bike if you have been riding it.
- Before you start work make sure you have protective clothes and eyewear.
- You will need the following tools to perform the installation: 8, 10 & 12mm T-Handles and 6mm Allen T-handle.

READ ALL INSTRUCTIONS BEFORE BEGINNING INSTALLATION

REMOVING YOUR STOCK SYSTEM

1. Place the machine on a stable work stand.
2. If you are not familiar with removing the original exhaust refer to the owner's manual before you start work.
3. Always allow your machine to cool down before attempting to remove the exhaust.
4. Remove the two bolts from the right side panel. Then remove the side panel.
5. Loosen the stock mid-pipe clamp, then remove the stand-off bolt and bracket bolt that supports the muffler.
6. Remove stock muffler and clamp from the stock head pipe.
7. Slightly loosen the stock head pipe at the cylinder head to aid in aligning the parts.

INSTALLING THE NEW XCR SYSTEM

1. Installer must use supplied hardware.
2. Slide mid-pipe onto head pipe. Rotate the mid-pipe slightly to obtain proper alignment with sub-frame mount.
3. Install the supplied M8x16mm bolt through sub-frame into the stand-off mount on mid-pipe (Finger tight).
4. Slide the muffler onto mid-pipe, align muffler mount with the stock muffler mount hole, and install and finger tighten the OEM bolt.
5. Once you have the system fully aligned, install and tighten all the bolts securely to factory specifications.
6. Replace the side panel and secure the mounting bolts.
7. Re-tighten stock head pipe at the cylinder head.

TEST RIDING

1. When you first ride the bike be aware that the characteristics are often quite different so start out slowly.

TUNING

1. On the KX450F, we suggest using stock jetting based on our testing condition. These specifications should only be used as a guideline. Riding at different elevations or climates may require using different settings to obtain peak performance. If you need additional assistance, please refer to your Kawasaki owner's manual.
2. To convert system from Offroad to Competition specifications, remove the 5mm Allen bolt and Spark arrestor. Two different Db lowering inserts are also available (see accessories section on page 2). To return the system to Offroad specification re-install the Spark arrestor into the rear of the muffler using a small amount of blue thread locking compound (Loctite® 243) re-tighten the 5mm Allen bolt (6.5 ft pounds).

MAINTENANCE NOTES

1. Exhaust mufflers require regular maintenance. Service intervals for repacking will vary with each application. Vance & Hines recommends repacking your muffler every 10 to 15 hours to ensure the system keeps running the way it was designed. Muffler repacking kits are available (see accessories section on page 2). This service interval will vary depending upon the speed, jetting specifications and the conditions in which you ride.
2. When repacking the XCR exhaust, remove end cap and repack through the end of the muffler.
3. The XCR spark arrestor must be serviced/ cleaned every 50 hours to maintain proper performance. See page 2 for complete instructions on how this is done.
4. When washing your machine, we recommend that the XCR end cap be covered to prevent water from entering into muffler and damaging the silencer packing.

SPARK ARRESTOR CLEANING

Warning:

Spark arrestor is extremely HOT. Do not try to clean spark arrestor until your muffler has cooled completely. Please read instructions thoroughly before beginning cleaning process.

Maintenance Notes:

The spark arrestor must be serviced/ cleaned to maintain proper performance. It is advised that your spark arrestor be cleaned every 50 hours. Failure to do so could lead to deterioration of the spark arrestor screen.

Tools:

4mm Allen key, Wire brush, Gloves, Eye protection.

Steps:

1. Remove spark arrestor assembly from rear of muffler using a 4mm Allen key. Bolt hole located at the rear of muffler on the bottom of the endcap.
2. Take wire brush and carefully clean all carbon buildup on the screen mesh of the spark arrestor. Inspect the spark arrestor for damage or tears in the screen. If present the spark arrestor will need to be replaced.
3. Once clean re-install the spark arrestor into rear of the muffler. Using a small amount of blue thread locking compound (Loctite® 243) retighten the 5mm Allen screw (6.5 ft pounds).

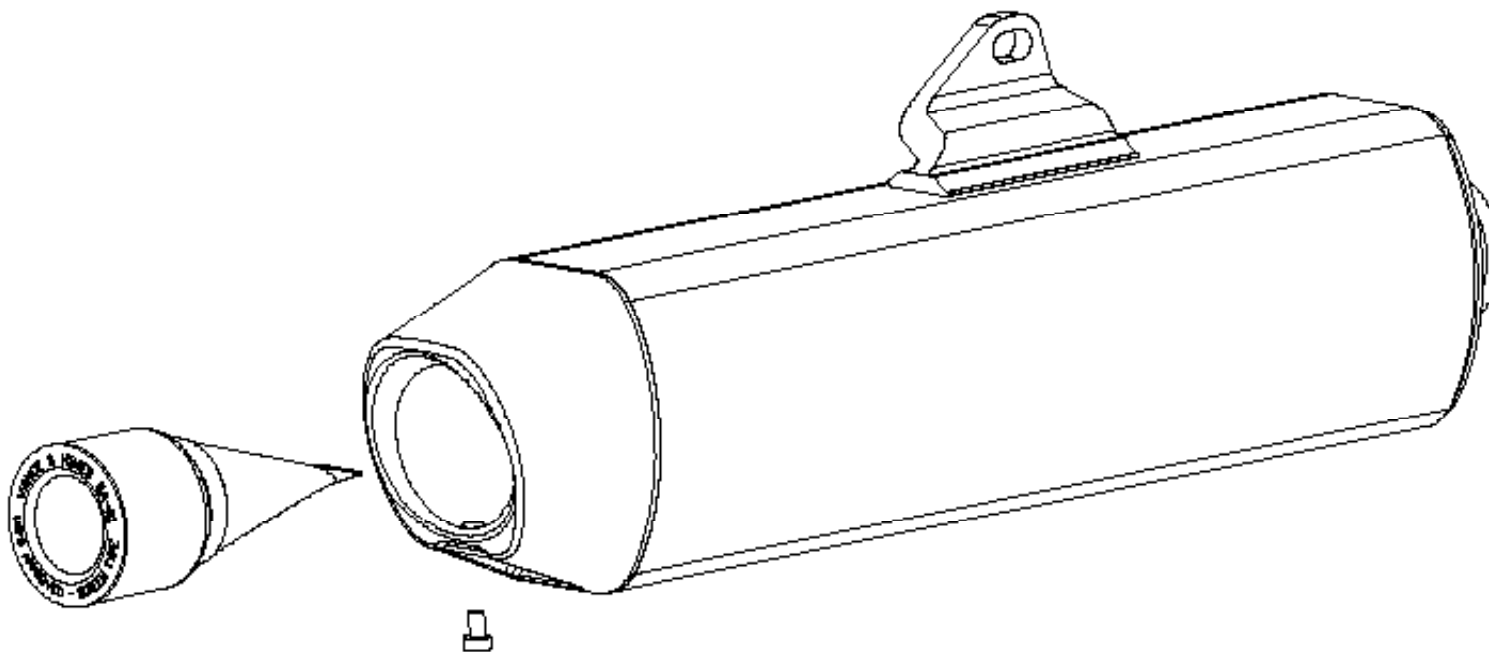

VANCE & HINES OPTIONAL ACCESSORIES

FUELPAK



For Fuel Injected models, maximize the efficiency of your improved air flow with properly managed fuel delivery by Fuelpak. Take the guess work out of fuel injection with Fuelpak Fuel Management. Contact your local dealer or call (562) 921-0071 to order. Visit fuelpakfi.com for more information. Fuelpak is intended for racing or off-highway use only, and is not legal for sale or use in California on pollution-controlled vehicles.

SPARE PARTS & ACCESSORIES

1. XCR Spark Arrestor Assembly P/N: 21881
2. 94 dB Sound Insert P/N: 21883
3. 99 dB Sound Insert P/N: 21885
4. Muffler Re-Pack Kit P/N: 21887

WARRANTY

All of our exhaust systems are warranted against defects in material and/or workmanship for a period of 90 days. This warranty shall be limited to the repair or replacement of the system, which may be proven defective under normal use. We will not warranty any system that has been abused, misused, improperly installed, or modified. Failure to follow muffler packing instructions and maintenance will also not be covered under warranty.