

CONGRATULATIONS! You have purchased the finest exhaust system available for your motorcycle. Your VANCE & HINES exhaust system is designed for today's rider, a rider who needs maximum performance, great styling and a perfect fitting system. Please follow the installation instructions below and if you have any questions, feel free to call our technical help line (562) 926-5291.

Attention Installer: (if other than owner): Please forward this instruction sheet to the purchaser of this product. These instructions contain valuable information necessary to the end user.



STOCK EXHAUST SYSTEM REMOVAL

1. This Exhaust system is specifically designed for California models, before continuing be sure it is the correct system for your application.
2. Loosen clamp that connects muffler to front head pipe.
3. Remove cylinder exhaust bolts from rear head pipe that connects rear head pipe to cylinder (save for re-use).
4. Remove bolts that connect mufflers to mounting bracket. Remove complete system. **Note:** Assistance may be required.

Tools required for installation:

1/2", 12mm & 10mm wrenches
5mm, 6mm Allen wrenches
5/16" nutdriver / flat blade
screwdriver

VANCE & HINES EXHAUST SYSTEM INSTALLATION

1. Check condition of stock exhaust gaskets. Replace if damaged or worn.
2. Install mounting bracket (stamped 370-P) in the original muffler mounting position, using two 8mm bolts (supplied)(Figure 1).

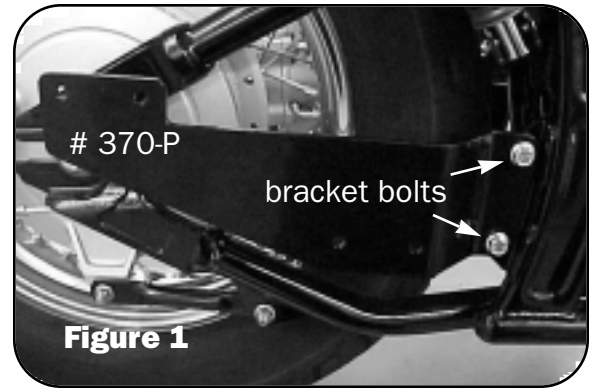

3. Mark outside surface of front and rear heat shields with location of mounting clips that are welded to the inside (Figure 2). Place each heat shield on a non abrasive surface such as a blanket or carpet. Lay each head pipe/muffler onto its respective heat shield (Figure 3).

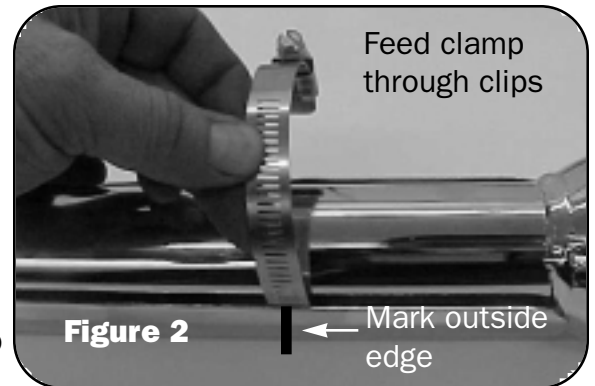

4. Loosely install each hose clamp by feeding tail end of clamp into heat shield clip (Figure 2). Take note of clamp screw head direction (Figure 3). Screw head should be accessible when system is installed on motorcycle for adjustment purposes. **Note:** Do not tighten yet.

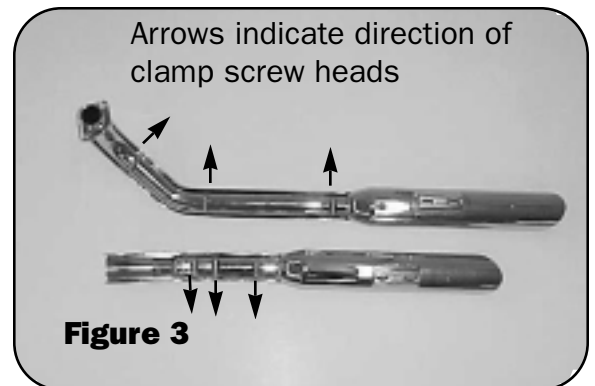

5. Install T-bolt clamp onto front muffler. Slide muffler onto front head pipe. Slide dog bone shaped nut plate (supplied) inside bracket welded to backside of front muffler. Attach muffler to mounting bracket 370-P using two 5/16" flange bolts (supplied) engaging dog bone nut plate. Leave head pipe/muffler assembly loose at this time (Figure 4).



6. Using stock Allen bolts, carefully install rear head pipe/muffler assembly into exhaust port. (Assistance may be required). **Note:** Do not tighten yet.
7. Slide dog bone shaped nut plate (supplied) inside bracket welded to backside of rear muffler (Figure 4).
8. Align mufflers so they are parallel when viewing from right side of the motorcycle. Tighten 5/16 flange bolts securing mufflers to bracket.
9. Tighten cylinder exhaust port bolts securing head pipes to cylinder head.

10. Tighten T-bolt clamp securing front muffler to head pipe.

11. Adjust heat shields so they meet front of muffler taper (Figure 5). Tighten all hose clamps securing heat shields. **Note:** Heat shields should cover muffler/head pipe weld joint. Adjust muffler if necessary to get heat shields to butt together evenly.

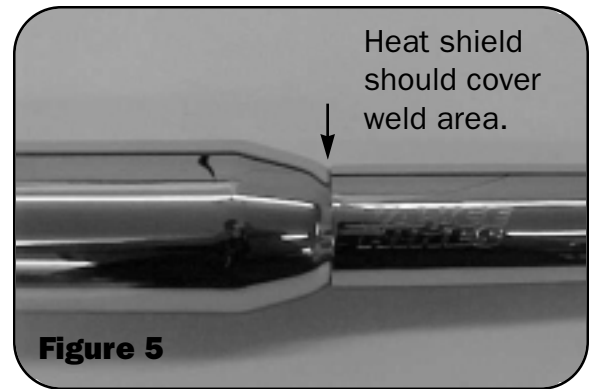

12. After installation and before starting motorcycle, completely clean pipes and mufflers with cleaning solvent and a clean, soft cloth that will not leave a residue. **Note:** Any residue, oil, or fingerprints will stain the chrome when the metal heats up.

13. **All hardware must be properly tightened before starting motorcycle.**

RE-JETTING INSTRUCTIONS

Re-jetting the carburetors will result in realizing the "full" potential of this performance exhaust system. Vance & Hines offers jet kits for most applications. For fuel injected models, we recommend the use of an adjustable fuel management system.

PLEASE NOTE: Every effort is made for Vance & Hines Exhaust Systems to provide improved cornering clearance. However, due to design and space limitations on some motorcycle models, (center stand, oil filter, oil pan etc.) ground and cornering clearance may not be improved and in some cases may be reduced. Be sure to follow proper installation instructions.

PACKING LIST (All parts actual size)

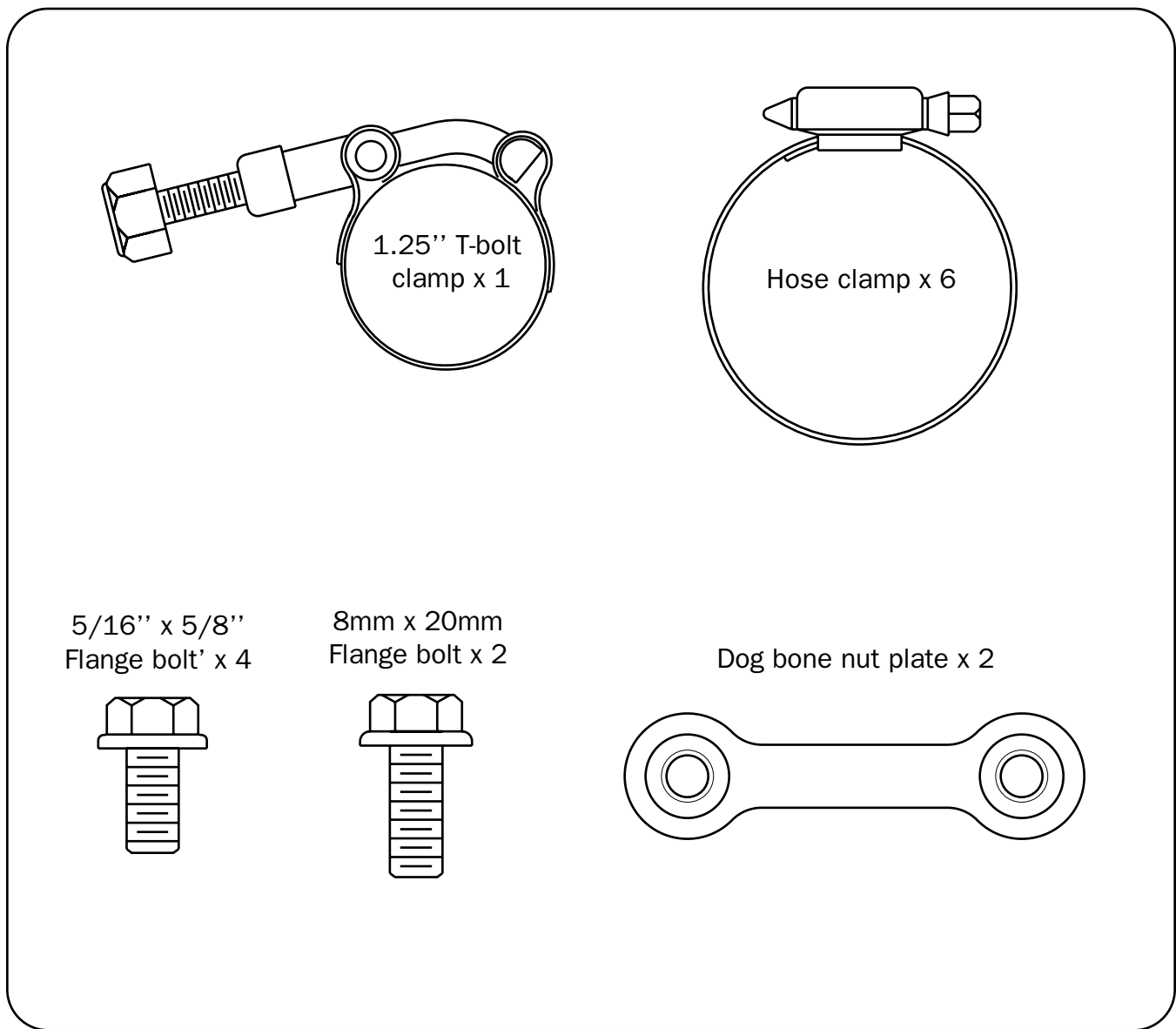

HELPFUL HINTS TO AVOID DISCOLORATION OF EXHAUST PIPES

1. Follow owner's manual instructions regarding use of the choke (starter enricher). If left on longer than recommended, discoloration may be accelerated.
2. Avoid long periods of idling.
3. Intake leaks can cause engine to run lean and overheat, thus turning the pipes blue.
4. Make sure there are no exhaust leaks at the junction of the exhaust pipe and cylinder head.
5. When installing a new set of chrome pipes, make sure your hands are clean and free of oil. After installation, thoroughly clean pipes with a cleaning solvent that will leave no residue (glass cleaner, alcohol, ammonia, etc.) before starting the motorcycle.

WARNING!

VANCE & HINES DOES NOT WARRANTY ANY CHROME PRODUCTS AGAINST DISCOLORATION.

For information about other Vance and Hines products visit our web site at www.vanceandhines.com